

GUARANTEE

Terms and Conditions for UK (outside UK contact your local distributor)

We, Applied Energy Products Limited, guarantee this product for **domestic use only**, for the period of 12 months from the date of purchase.

Within the guarantee period we will resolve, **free of charge**, any manufacturing defects in the product resulting from faulty workmanship or material on condition that:-

- a) The appliance has been correctly installed in accordance with our instructions and is being used on the supply circuit or voltage printed on the rating plate.
- b) The appliance has been used in accordance with these instructions and has not been tampered with or otherwise subject to misuse, neglect or accident.
- c) The appliance has not been taken apart, modified or repaired except by a person authorised by us.
- d) Evidence of the date of purchase in the form of an invoice or receipt will be required in order to qualify for an in-guarantee repair.
- e) For the service work to be undertaken free of charge, the work must be only undertaken by Applied Energy Products Limited, or our approved agents.
- f) Service under guarantee has no effect on the expiry date. The guarantee on any exchanged parts or product ends when the original guarantee period ends.

EXCLUSIONS

This guarantee **DOES NOT** cover damage or defects arising from poor or incorrect installation, improper use or lack of maintenance, including build-up of limescale. It is the responsibility of the installer to check that the installation parameters meet the requirements of the product, and any relevant regulations.

If we are called out to a fault, which is subsequently identified as being an installation fault, we will make a charge. It is important that the routine checks are completed before calling us out, as many issues can be simply diagnosed and resolved.

We make no guarantees as to response times for repairs. We will endeavour to achieve the most timely response possible but while we indicate an average response time, this should not be taken as a guarantee.

The guarantee applies to a repair or replacement (at our discretion) of the product subject to the conditions above, and **DOES NOT** cover compensation for the loss of the product or consequential loss of any kind.

The guarantee does not apply to the repair or replacement of pressure relief devices, sprayheads, hoses, accessories, isolating switches, electrical cable, fuses and/or circuit breakers.

This guarantee does not affect your statutory rights.

Full details of terms and conditions are available on request from: -



APPLIED ENERGY PRODUCTS LIMITED
MORLEY WAY, PETERBOROUGH PE2 9JJ
TEL +44 (0) 01733 456789 / FAX: +44 (0) 1733 310606
Website: www.creda-heating.co.uk

We offer a technical advisory service on the telephone to installers and other customers with problems in the field. RING 0870 9000 430 (UK ONLY)



Florida
Spa

SHOWER HANDBOOK

IMPORTANT:

This booklet should be left with the user after installation and demonstration.

Thank you for choosing a quality Creda product manufactured in Peterborough, England

Contents

Information for the user	Page
How to use your Creda Shower	2
How your Creda Shower Works	3
What to do if things go wrong	4
How to maintain your Creda Shower	4
Additional Accessories / Spare Parts	7
Information for the installer	
Fixing the Shower to the wall	5
Plumbing	6
Electrical	6
Guarantee	8

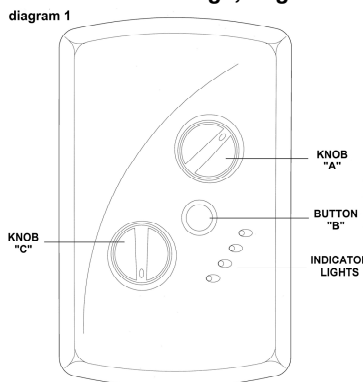

How to use your Creda Shower

- Ensure the electricity and water are turned on to the unit.
- Your shower has 3 power settings selected by turning knob "A". The most popular is "FULL HEAT" indicated by "●" and for your convenience this can be obtained in 2 positions so you are always only one step away from maximum power. There are also options for a "HALF HEAT" or "COLD" shower (see notes 8 and 9). **For this example turn knob "A" to "FULL HEAT" (either will do) and set knob "C" to "6 o'clock" on the scale.**
- Press button "B"**. Water will flow, 3 lights will illuminate to indicate that the selected power rating is "FULL HEAT".
- Allow about 20 seconds** for the temperature of the water to stabilise. It is recommended that you do not wholly enter the water spray during this period, even if the shower has just been used.
- If the water is **too hot**, then increase the flow of water by **turning knob "C" clockwise** to "7 o'clock" on the scale. **Wait 20 seconds** for the temperature of the water to stabilise. Repeat turning clockwise if necessary until you get the water temperature of your liking.
- If the water is **too cold**, **turn knob "C" anti-clockwise** to "5 o'clock" on the scale and continue as necessary until you get the water temperature of your liking. The final adjustment may be anywhere on the scale.
- Basically turning knob "C" **anti-clockwise increases** the water temperature, whilst turning **clockwise decreases** the water temperature.
- Once a temperature setting to your liking has been achieved, knob "C" will rarely need adjusting, eg: adjust for variations of incoming mains water temperature between summer and winter.
- When you have **finished** showering, push **button "B" only**. You have no need to adjust knobs "A" or "C". Switch off the electricity at the ceiling switch or local isolator.
- The "HALF HEAT" setting of knob "A" reduces the power used by the shower giving a cooler shower or the option of reduced water flow. This option is mainly for summer usage and if this is used then knob "C" must be re-adjusted. On this setting 2 lights will illuminate to indicate that the selected power rating is "HALF HEAT"
- The "COLD" setting indicated by "○" of knob "A" will supply water without any heating, and only 1 light will illuminate to indicate this.
- Your shower is **designed to stabilise temperature** changes caused by water pressure fluctuations. These can result from toilets being flushed or taps being turned on and off. When this happens your showering temperature will be held within a controlled band, provided that the minimum pressure required by the shower is maintained.
- Your shower requires a minimum operating pressure of 69kPa (0.7 bar, 10 psi). At pressures above 69kPa (0.7 bar, 10 psi) it will minimize temperature fluctuations as detailed above in note 10. If the water pressure falls below 69kPa (0.7 bar, 10 psi) it is likely that the pressure switch will turn off the power to the heating elements, resulting in a cold shower. The 2 middle power indication lights will flicker and go out and the "OVERHEAT" light may come on to indicate this has happened.
- During normal operation if an overheated water temperature is sensed by the shower then the thermal cut-out will switch off the heating elements. The "OVERHEAT" light will illuminate to provide a visual indication that this has taken place. Water will continue to flow and as the water temperature falls the heating elements will be turned back on. If the "OVERHEAT" light continues to cycle then turn knob "A" to the "HALF HEAT" power setting (knob "C" will need adjusting). If the shower is operated after it has recently been used the "OVERHEAT" light may illuminate for a few seconds. This indicates that there is still some hot water left in the shower. Either, wait a few moments for the light to go out or turn knob "C" clockwise.
- Note that knob "C" **IS NOT A TAP** and does not turn the water off.

**WARNING: DO NOT SWITCH THE SHOWER ON IF YOU SUSPECT IT OF BEING FROZEN.
WAIT UNTIL YOU ARE SURE IT HAS THAWED OUT**

4. WARNING: THIS APPLIANCE MUST BE EARTHED

- Fit the corner section back into the backplate
- Fit the front cover back into position making sure the knobs are aligned correctly with the flow valve and power selector (see diagram 10). Start by locating the "tang" around the recess for the outlet pipe, and then "roll" the front cover over the knobs and onto the top of the backplate. Secure the top and bottom fastening screws.
- Operate the shower first without the handset to flush out particles, fit the handset and then operate the shower as on page 2 and check:
 - That the water gets to a satisfactory temperature.
 - Water flow can be adjusted by knob "C".
 - Power selection does give a change in water temperature and power lights illuminate.
 - Check again for leaks
 - That the holes in the spray plate are not blocked

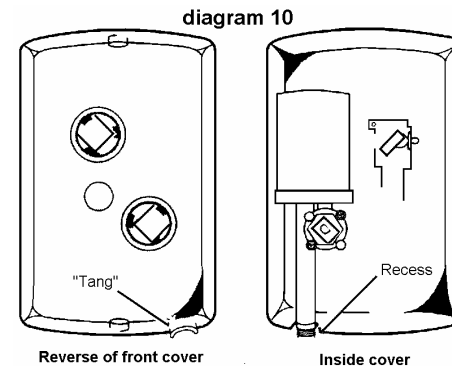

8. DEMONSTRATE OPERATION TO USER

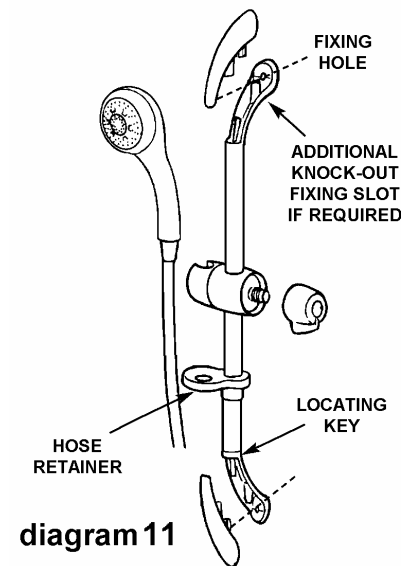

Additional Accessories / Spare Parts

White 2 metre Shower Hose	Catalogue No. 83-593529
1 metre Riser Rail	Catalogue No. 83-593530
Extended Shower Control Lever (Interchangeable with Control Knob)	Catalogue No. 83-590710
WRAS listed Water Isolating Valve	Catalogue No. 93-792452
Curtain and Rail Pack	Catalogue No. 83-792802
Curtain and Rail Pack with Non-Slip Mat	Catalogue No. 83-792801
Spare 1.25m long Chrome Shower Hose	Catalogue No. 93-797641

Spare parts/accessories can be supplied against any Credit or Debit cards from Sales Hotline 0870 9000 420

This appliance is not intended for use by persons (including children and the infirm) with reduced physical, sensory or mental capabilities, or lack of experience and knowledge, unless they have been given supervision or instruction concerning use of the appliance by a person responsible for their safety.

Children should be supervised to ensure that they do not play with the appliance.

b. Plumbing

The heater must be connected to the mains cold water supply. This must have a minimum running pressure of 69kPa (0.7 bar, 10 psi) and a maximum pressure of 690kPa (7.0 bar, 100 psi).

Before connecting the pipe work to the shower, ensure that pipe work is flushed out.

- It is recommended that a WRAS (Water Regulations Advisory Scheme) listed isolating valve is fitted to the incoming mains cold water before the shower unit. This will allow the unit to be serviced or exchanged without having to turn off the water at the water stop valve.
- The heater can be fed from a header tank provided this has a minimum head of 7 metres (23ft).
- Ø15mm copper or stainless steel pipe should be used. To avoid cross threading, **DO NOT REMOVE** the brass nut from the elbow when positioning the pipe. If top entry is required, turn the elbow 180° into the required position. If rear entry is required, treat as top entry with an additional "Yorkshire" elbow (soldered type) for fitting into the rear channel. In multiple installations, correct pipe work sizes should be calculated to maintain adequate flow to each shower.
- It is permissible to use a WRAS (Water Regulations Advisory Scheme) approved sealant sparingly whilst avoiding excess finding its way into the shower operating parts.
- With isolating valve connected, **flush the pipe work through to remove any particles etc.**, before making the final connection to the shower. Blockage in the water ways (particularly the handset and solenoid valve) will prevent the heater working properly. *Note: You may be charged for a service call if it is due to incorrect installation.*
- The shower is designed to have an open outlet and should only be used with "Creda" recommended fittings. Do not connect the handset until after the shower front cover and corner section are fitted.

WARNING: DO NOT FIT A TAP ON THE SHOWER OUTLET.

TAKE CARE TO AVOID RESTRICTING THE OUTLET OF THE PRESSURE RELIEF DEVICE

c) Electrical

The electrical installation must be in accordance with the current BS.7671 (IEE Wiring Regulations), and Part "P" of the Building Regulations.

- The shower is designed for a single phase AC electrical supply. Check the unit rating plate to see which applies. (** Only applies if external earth impedance is less than 0.35 Ohms*)

Rating	Cable Sizes	Fuse / MCB	Cable Length
7.2 / 6.6kW 240 / 230V	4.0mm ²	32A Type B MCB	21m Max.
	6.0mm ²		35m Max.
	6.0mm ²	40A Type B MCB	27m Max.
	10.0mm ²		45m Max.
8.5 / 7.8kW 240 / 230V and 9.5 / 8.7kW 240 / 230V	6.0mm ²	40A Type B MCB	27m Max.
	10.0mm ²		45m Max.
	6.0mm ²	45A BS.1361 fuse	12m Max.*
	10.0mm ²		21m Max.*
10.5 / 9.6kW 240 / 230V	10.0mm ²	45A BS.1361 fuse	12m Max.*

Remember to upgrade the cable if it runs in thermal insulation in a loft, or for a longer distance.

- A means for disconnection in all poles must be incorporated in the fixed wiring in accordance with the wiring rules. We recommend a ceiling switch mounted in a convenient position.
- Cut back cable as in diagram 9. Connect cable to terminal block making sure that all the retaining screws are **VERY TIGHT** and that no cable insulation is trapped under the screws.

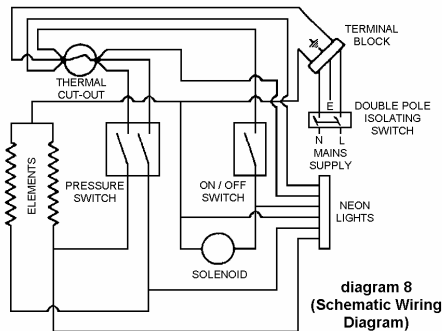

diagram 8
(Schematic Wiring Diagram)

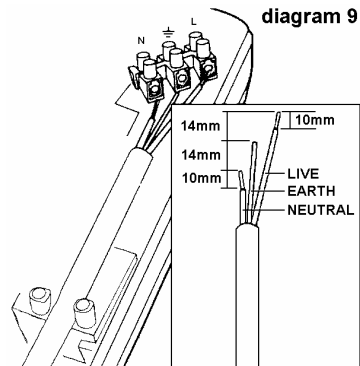

diagram 9

How your Creda Shower Works

Your shower is designed for convenience, economy and safety of use.

- Water is heated instantaneously as it flows over the heating elements in the copper cylinder (diagram 2)

diagram 2

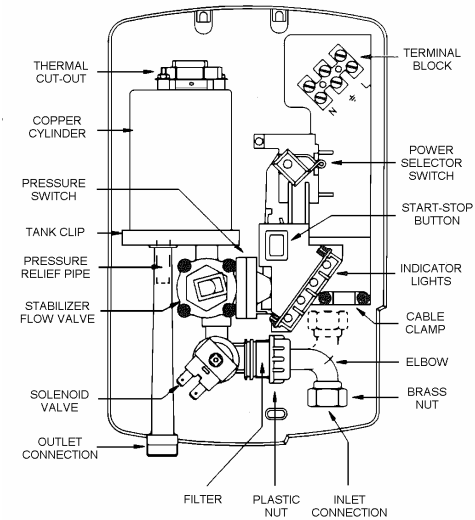

- The required water temperature is achieved by adjusting the rate of water flow. Diagram 3 shows the principle involved in relating temperature rise to flow rate. The higher the water rate the lower the temperature rise and vice versa. The temperature of the water supplied from the mains can vary considerably throughout the year from 5 to 20°C. This means that in the winter, flow rate will be less than in the summer to achieve the same outlet temperature. In summer the "HALF HEAT" power setting may give adequate hot water.
- The heaters are only switched on when sufficient water is flowing. This is done automatically with a switch which works on water pressure and is indicated by 2 or 3 lights illuminating depending on knob "A" power selection.
- The water is turned on and off by the solenoid valve built into the shower. This is switched on by button "B".
- The flow of water is automatically held at the level set by the user even though the supply pressure may vary (See "How to use your shower" note 10).
- If the water supply falls below a set limit, the pressure switch will operate and switch off the power to the elements. This is indicated by the middle power setting lights flickering and going out (see "How to use your shower" note 11).
- As a further safeguard, a thermal cut-out switches the power off if the water temperature climbs above the set limit and the "OVERHEAT" light will come on. This cut-out, which gives an audible click, may also operate due to residual heat when the shower is switched off. It will reset itself if water is run through the shower for 10 to 20 seconds, and the "OVERHEAT" light will go out.
- The pressure relief device is to safeguard against abnormal pressure conditions, and provides a level of appliance protection should an excessive build up of pressure occur within the shower.

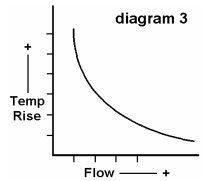

diagram 3

IN ORDER TO MAINTAIN THE PERFORMANCE OF YOUR SHOWER, YOU MUST CLEAN THE SHOWERHEAD REGULARLY.

All water contains particles of lime-scale, which build up in the showerhead and unit reducing the performance. It is therefore important to clean the showerhead by simply rubbing the rubber nozzles, or soaking in a proprietary lime-scale remover and rinsing thoroughly before use.

NOTE: After use it is normal for some water to drip from the showerhead for a few moments. This inhibits lime-scale build-up over prolonged use.

What to do if things go wrong

SELF HELP

If the shower is not working satisfactorily, make the following checks before calling out the contractor. Any one of these adjustments could restore the performance.

a) The shower cycles from HOT to COLD	The shower temperature is set too hot causing the thermal cut-out (safety device) to operate. Turn the temperature knob fully clockwise to increase the water flow. "HALF HEAT" setting may need to be selected. Slowly increase the water temperature by turning knob anti-clockwise until a comfortable showering temperature has been reached. You MUST WAIT approximately 20 seconds for each adjustment to affect the water temperature.
b) Water too HOT	Increase water flow by adjusting the temperature control clockwise. Clean showerhead holes. Select outer or combination spray pattern. Switch power to "HALF HEAT" setting. Increase pressure to water supply e.g. fully open service valve or stop cock. Check hose is not kinked restricting the water flow.
c) Water too COLD	Decrease water flow by adjusting the temperature control anti-clockwise. Switch power to "FULL HEAT" setting.
d) Spray pattern poor	Clean showerhead and flush heater.
e) Water takes longer to heat up	Thermal cut-out has operated after previous use ("OVERHEAT" light is on). Will automatically reset when unit cools down. Switch power to "FULL HEAT" setting.
f) Water goes cold while using shower	Check power setting lights are on. Check water pressure has not fallen so far as to let pressure switch cut out, e.g. Another tap drawing water off. Raise position of handset.
g) Broken parts	Please contact our spares department on 0870 9000 420. Fitting instructions are provided

PROFESSIONAL SERVICE

If the above checks fail to restore the performance, you should seek professional help.

The person who installed the shower is probably the best one to investigate and correct it, and is certainly the person to contact if you have had a problem in the guarantee period.

The following additional checklist is provided for the benefit of the qualified service person.

WARNING: SWITCH OFF THE ELECTRICITY AT THE ISOLATOR BEFORE REMOVING THE COVER TO MAKE CHECKS

a) Water too HOT	Water flow restricted by blockage in filter of solenoid valve. Switch off water, loosen inlet connection to solenoid, remove filter in solenoid with long nosed pliers and flush clean.
b) Water too COLD	Check circuit through thermal cut-out. Check circuit through microswitches on the pressure switch. Check each element circuit. Check tightness of electrical connections.
c) No control over water flow	Undo headworks of stabiliser valve. Check stabiliser is in place and remove any debris in valve.
d) Water discharges from pressure relief valve	Check for cause of high pressure and remove it. Blockage on outlet e.g. blocked showerhead. Replace the pressure relief disc (not covered by guarantee).
e) Water does not flow when button "B" is pressed.	Check circuit through solenoid coil. If defective then replace. Check circuit through microswitches. If defective then replace. Power supply not reaching shower.

After Sales Service

We offer a technical advisory service on the telephone to contractors and other customers with problems in the field. **RING 0870 9000 430**

Spare parts can be supplied against Credit or Debit cards. **RING 0870 9000 420**

Remember to quote the exact type of shower, as written on the front face. The model and serial number are located on the bottom face of the shower. Make a note of those numbers, and quote them if you call for advice.

Model No: 53-..... / Serial No:.....

Note: You may be charged for a service call if you do not have a serial number.

How to maintain your Shower

It is recommend that the shower unit, riser rail, hose etc. be cleaned using a soft cloth and that the use of abrasive or solvent based cleaning fluid be avoided, especially on any plated finishes.

We recommend that before any cleaning, the isolating switch be turned off, thus avoiding accidentally switching on the shower.

The showerhead should be periodically cleaned as detailed on page 3.

YOU MUST REGULARLY INSPECT THE SHOWER HOSE FOR WEAR AND DAMAGE. REPLACE IF NECESSARY, OR EVERY TWO YEARS, WITH OUR APPROVED PART.

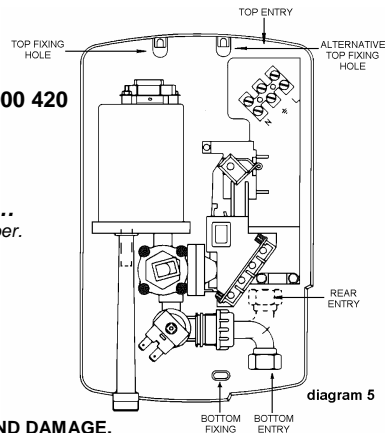

diagram 5

Installation Instructions

ALL WIRING AND INSTALLATION MUST BE SUPERVISED BY A QUALIFIED ELECTRICIAN

WARNING: DO NOT INSTALL THIS SHOWER IN A ROOM WHERE IT MAY BE SUBJECT TO FREEZING.

We recommend that the installation is done in the following sequence.

- Fixing the shower to the wall
- Plumbing
- Electrical connections

a. Fixing the shower to the wall

1. Position the riser rail at a convenient height for majority of users as detailed in diagram 6 and mark its position.

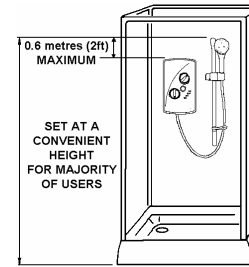

diagram 6

2. Position the heater so that the top of the unit is horizontal and level with, **or up to 0.6 metres (2ft) maximum below the top of the riser rail.** Choose a flat piece of wall to avoid the possibility of distorting the backplate thus making the front cover a poor fit.

3. Adjust the position to get the most convenient arrangement taking the following into account.

- The possible need to use the handset over the sink for hair washing etc.
- The heater must not be mounted in the direct spray from the handset.**
- The handset must not be able to come into contact with used water in the cubicle, bath or basin. If it can, even after the hose has been retained by the hose retainer (see diagram 11), then a vacuum breaker must be fitted. It should be noted that these devices are liable to minor leakage so they must be positioned so that any drips are not detrimental.

4. Fix the riser rail with screws provided. The fixing holes at the base of the brackets will be disclosed by removing the plastic fronts. Assemble as shown in diagram 11.

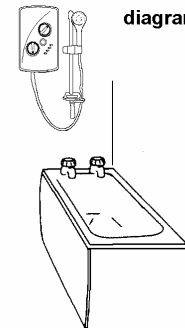

diagram 7

5. Decide the position of the electrical cable to the unit. If top or bottom entry is chosen (according to diagram 5), cut away the walls in the backplate as shown in diagram 7.

6. Decide the position of entry of the cold water pipe into the unit. If top, cut away the backplate. If rear, please read the section on plumbing. If bottom, remove the front cover (complete with knobs) and cut away the detachable corner section as shown,

7. If you have not yet done so, remove the front cover (complete with knobs) of the unit by undoing the retaining screws at the top and bottom of the unit and lifting the cover off. Your shower is provided with 2 fixing positions in the backplate (see diagram 5).

The top-fixing hole is a "key-hole" slot (another key-hole is provided for alternate fixing), and should be marked and drilled first. Tighten top screw with head protruding about 10mm from the wall and hook the backplate over the screw head. This allows for correct and accurate alignment of your shower before marking and fixing the bottom position.

You may not wish to tighten up both screws at this stage as the holes are elongated to allow for adjustment after other connections have taken place.

